



Installation - Manual

XV - Acoustic Housing

**Solflex GmbH
Am Feuerstein 282
2392 Wienerwald
Austria**

**T: +43223820336
E: office@solflex.eu
www.solflex.eu**

**ATU 65324348
FN 337206t**

**Always observe all relevant standards and
statutory regulations**

Subject to change without prior notice.
All business transactions based on our Terms and Conditions, available at
www.solflex.eu

Inhalt

1.	General information.....	4
2.	Technical data	4
3.	Warranty.....	7
4.	Safety.....	7
4.1	Intended use	7
4.2	Safety instructions	7
4.2.1	Risks during unloading and transportation.....	7
4.2.2	Risks of damage to property and environment	7
4.3	Emergency procedure.....	7
4.3.1	Fire fighting.....	7
5	Product delivery	7
5.1	Unloading / transport to location of installation	8
5.2	Unloading with a forklift or pallet truck	8
5.3	Unloading with a crane	9
5.4	Manual positioning	10
6	Installation of unit	11
6.1	Installation site	11
6.2	Foundation.....	12
6.3	Installation.....	12
6.4	Adjusting the feet.....	13
6.5	Installation of refrigeration, air conditioning and heat pumps... 14	
7	Maintenance and Service.....	18
7.1	General.....	18
7.2	Silencers	18
7.3	Air separation	18
7.4	Drain pan.....	18
7.5	Grounding	19
7.6	Test run	19
7.7	Removal and disposal	19
7.8	Maintenance table	19

1. General information

Solflex produces acoustic housing for a wide range of Heat Pump, Air Conditioning and Refrigeration systems. This manual applies to the following series:

Solflex XV* Serie

<https://solflex.eu/en/Xvschalldaemmgehaeuse23db>

2. Technical data



Stable self-supporting, insulated box housing with fully demountable structure without welding and riveting. All housing components are resistant to corrosion using galvanized steel sheets and aluminium. Profile frame construction with mechanically loaded all sides easily removable panels in sandwich construction. Inner surfaces are fully lined with sound-absorbing material. Frame constructed of solid hollow profiles made of anodized aluminium. The extruded profiles are fitted at the corners by, in accordance with its interior, moulded connectors made of cast aluminium. The box housing is pre-mounted on a stable base frame made of high-strength, galvanized steel profiles. The base frame is designed with height-adjustable, sturdy feet and to be placed on a firm ground. Exact separation of the suction and discharge air flow provided by a flexible, tailor-made, airtight air separator between the upper lamella-pack and the outdoor unit. The flexible air separator is fixed by the installation company on the outer edge of the outdoor unit with foam rubber band and tapping screws, included in the delivery. Integrated special designed lamella-pack sets on both sides and at the back side for large-scale and laminar air intake, as well as on the top side of the housing for air discharge with same integrated silencing baffles. Sound insulation made of high-quality material combination for the absorption of airborne sound. Fire behavior according to DIN4102 A2. The lamella-packs can easily be removed from the box housing for easy access for operation and maintenance of the outdoor units (condensers and fans) with the built-in quick-release fasteners. The front side of the housing is fitted with isolated, large doors for optimal access and installation of outdoor units. Cables and pipes of the outdoor unit can be put through on 3 sides (left, right and back side) of the housing. The complete construction is completely weatherproof. For safe loading and positioning several stable crane lugs are mounted on the base frame.

Solflex Type	Housing dimensions H x W x D [mm]	Weight [kg]	Max. dimensions for installation * H x W x D [mm]	Equipment
XV100NA	2400 x 2560 x 1850	845	1700 x 1000 x 850	1
XV200NA	2400 x 2960 x 1850	1040	1700 x 1400 x 850	1
XV110NA	2400 x 3760 x 1850	1430	1700 x 1000 x 850	2
XV210NA	2400 x 4160 x 1850	1560	[1700 x 1400 x 850] + [1700 x 1000 x 850]	2
XV220NA	2400 x 4560 x 1850	1690	1700 x 1400 x 850	2
XV111NA	2400 x 4960 x 1850	1950	1700 x 1000 x 850	3
XV211NA	2400 x 5360 x 1850	2080	[1700 x 1400 x 850] + 2 x (1700 x 1000 x 850)	3
XV221NA	2400 x 5760 x 1850	2210	2 x [1700 x 1400 x 850] + [1700 x 1000 x 850]	3
XV222NA	2400 x 6160 x 1850	2300	1700 x 1400 x 850	3

Solflex Type	Housing dimensions H x W x D [mm]	Weight [kg]	Max. dimensions for installation * H x W x D [mm]	Equipment
XVX100NA	2600 x 2860 x 2050	910	1900 x 1300 x 1050	1
XVX200NA	2600 x 3300 x 2050	1105	1900 x 1750 x 1050	1
XVX110NA	2600 x 4360 x 2050	1625	1900 x 1300 x 1050	2
XVX210NA	2600 x 4800 x 2050	1755	[1900 x 1750 x 1050] + [1900 x 1300 x 1050]	2
XVX220NA	2600 x 5260 x 2050	1885	1900 x 1750 x 1050	2
XVX111NA	2600 x 5860 x 2050	2015	1900 x 1300 x 1050	3
XVX211NA	2600 x 6300 x 2050	2145	[1900 x 1750 x 1050] + 2 x [1900 x 1750 x 1050]	3
XVX221NA	2600 x 6760 x 2050	2236	2 x [1900 x 1750 x 1050] + [1900 x 1300 x 1050]	3
XVX222NA	2600 x 7260 x 2050	2366	1900 x 1750 x 1050	3

Solflex Type	Housing dimensions H x W x D [mm]	Weight [kg]	Max. dimensions for installation * H x W x D [mm]	Equipment
XVY100NA	2800 x 2560 x 2050	975	2100 x 1000 x 1050	1
XVY200NA	2800 x 2960 x 2050	1170	2100 x 1400 x 1050	1
XVY110NA	2800 x 3760 x 2050	1625	2100 x 1000 x 1050	2
XVY210NA	2800 x 4160 x 2050	1755	[2100 x 1400 x 1050] + [2100 x 1000 x 1050]	2
XVY220NA	2800 x 4560 x 2050	1885	2100 x 1400 x 1050	2
XVY111NA	2800 x 4960 x 2050	2080	2100 x 1000 x 1050	3
XVY211NA	2800 x 5360 x 2050	2210	[2100 x 1400 x 1050] + 2 x [2100 x 1000 x 1050]	3
XVY221NA	2800 x 5760 x 2050	2340	2 x [2100 x 1400 x 1050] + [2100 x 1000 x 1050]	3
XVY222NA	2800 x 6160 x 2050	2470	2100 x 1400 x 1050	3

3. Warranty

24 months from delivery.

4. Safety

Bei unsachgemäßer oder nicht bestimmungsgemäßer Verwendung können Gefahren für Leib und Leben des Benutzers oder Dritter bzw. Beeinträchtigungen des Gerätes und anderer Sachwerte entstehen.

4.1 Intended use

The unit must only be used as acoustic housing for compatible Heat Pump, Air Conditioning and Refrigeration systems. Any other use is strictly prohibited.

4.2 Safety instructions

All work about the assembly, installation and commissioning of the unit must be carried out by specially trained technicians.



It is possible to get injured during the mounting because of the metal execution and processing. Please wear gloves.

4.2.1 Risks during unloading and transportation



Risk of serious injury from dislodged loads. Do not stand under suspended loads.

Risks from electric power.
Risk of electric shock from electrostatic charge of housing.

Earth the device.

4.2.2 Risk of damage to property and the environment



Serious damage to property from dropping loads;
Please observe the instructions in section "Delivery of product".

Serious damage to heat exchanger connections, paneling and other mounted components from the force impact during moving of unit elements; **always move the unit elements by their base frame.**

Risk of damage to components from heavy impact, e-g- when attempting to dislodge a part with a hammer, etc.: **Components that rest on the foundation must only be moved by shifting.**

4.3 Emergency procedures

4.3.1 Fire fighting

Strictly adhere to all statutory fire safety regulations.
The insulation foam has a fire behavior according norm.

5 Product delivery

Upon delivery, inspect the product for damage caused during transport and ensure that the delivery is complete. Record any damage or missing parts on the transport documents. Complaints regarding obvious transport damage or incomplete deliveries cannot be considered if made too late.

On the construction site, protect the unit against dirt, impact and the elements.

5.1 Unloading / transport to location of installation

Dieses Schalldämmgehäuse wird zerlegt auf einer Palette geliefert. Beim Abladen darf die Anhebe kraft nur auf einer Palette erfolgen. Zu kurze Gabeln können das Schallschutzgehäuse zerstören.



Risk of serious injury or damage to property from dropping loads. Observe the safety instructions of the transport equipment and lifting gear.

Base frame

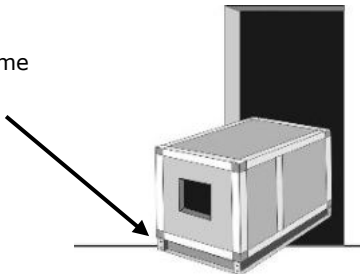

Products must not be lifted by the connections.

Do not climb onto the unit, if unavoidable: distribute weight by placing boards underneath.

5.2 Unloading with a forklift or pallet truck

It is important to ensure that the products base frame rests completely on the forks of the lifting device and the center of gravity lies between the forks. When unloading, make sure that the profiles do not get damaged. If the forks are too short they can damage the drain pan.

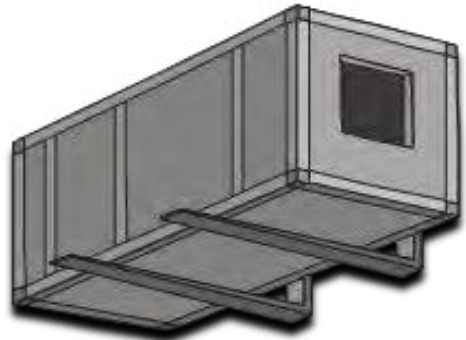

5.3 Unloading with a crane

Only suitable and approved lifting accessories (ropes, lifting straps, ...) may be used. Use spacers to protect the acoustic housing from damage.



The specially provided crane lugs are to be used to transport the acoustic housing. These may not be mounted on the upper corner connections.

Schematic figure, please note the description above!

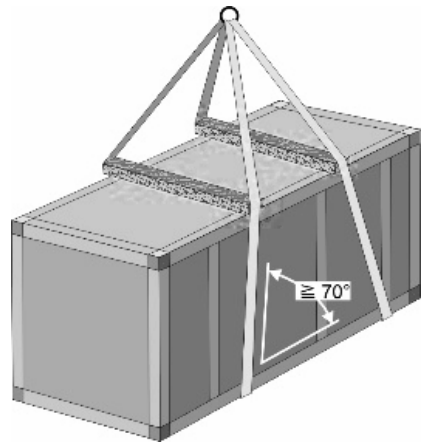

There are 3 different variations of lifting accessories:

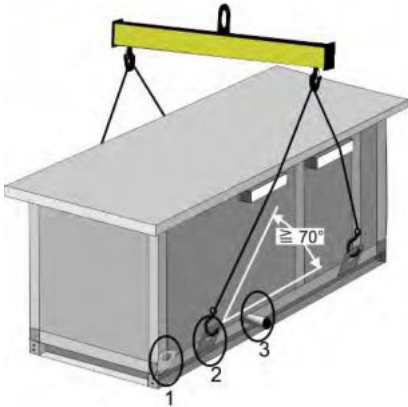

Variation 1
Crane strap on the corner bracket

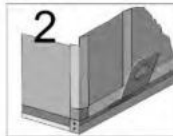

Variante 2:
Crane strap on the base frame

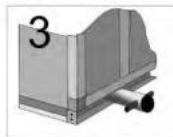

Variante 3:
Form tube through base frame

Larger acoustic housings are equipped with 8 lugs, please note the figure.



5.4 Manual positioning

When moving the acoustic housing, the force must not act on connections and panels. The force should always act on the base frame.

Never move the acoustic housing with blows from heavy equipment (e.g. hammer).

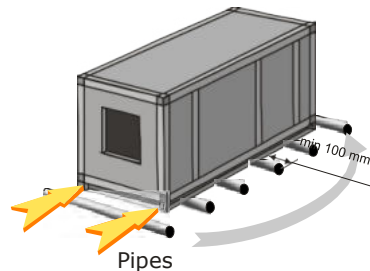
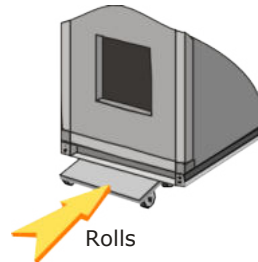

6 Installation of unit

NOTICE

At the place of installation, it must be possible to provide impeccable service and maintenance and the necessary air intake of the built-in air-conditioning, refrigeration and heat pump units.

When planning the installation site, the guide lines for minimum distances around the air-conditioning, refrigeration and heat pump manufacturer must be respected.

Suitable options must be created on site for frost-proof draubage if tge condensate.

The transport wedges must be removed before the sound enclosure is fitted at the installation site.



Important NOTE:

NOTICE

Please always use the required safety work gear during installation. Due to the packaging materials and the production process, personal injury may occur, such as hand injuries. If the soundproof housing is freely accessible, the necessary measures during assembly should be taken to local conditions to avoid personal injury.

6.1 Installation site

The following minimum distances to walls must be observed:

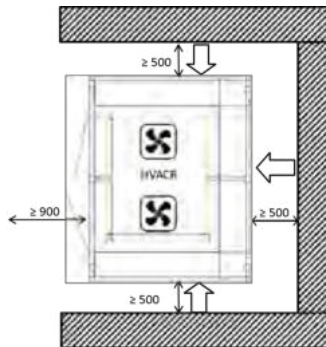

6.2 Foundation

The foundation must meet the relevant static and sound propagation requirements and must feature a proper drain for water. It must be level and smooth. The resonance frequency of the support structure must be distinctly different from the excitation frequency of the rotating machine components (Heat Pump, Air Conditioning and Refrigeration system).

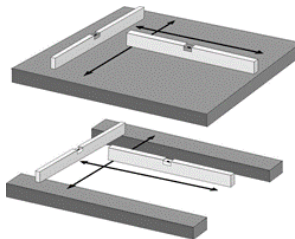

An uneven foundation might cause malfunction or jammed panels. Liability is excluded for damage caused by installation on an uneven surface.

6.3 Installation

All housings are fully assembled at the factory and can easily be set up on a foundation, such as a strip foundation or concrete slabs on a solid surface- A separate base frame is usually not necessary, unless it is a roof installation where a special load distribution is necessary.



The base frame and the crane lugs are statically designed and dimensioned so that the air conditioning, cooling and heat pump devices can be pre-assembled in the soundproof housing and lifted together with the crane. No liability will be accepted for any errors or consequences resulting from the fixing and checking of the fixing of the cross member and the pre-assembly of the air conditioning, refrigeration or heat pump units.

6.4 Adjusting the feet

The housings can be aligned horizontally on the ground using adjustable feet on the base frame.



The lock nuts must be retightened on all feet on the construction site and checked for correct fit and firmness.

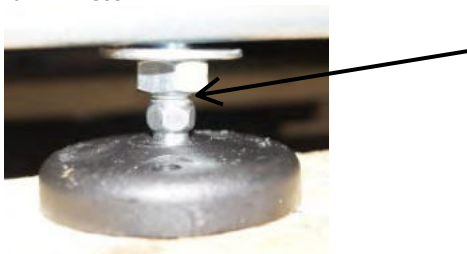

6.6 Installation of refrigeration, air conditioning and heat pumps

The correct installation position of the air conditioning, refrigeration or heat pump device is decisive for the fit and function of the sound insulation housing.

WARNING

Depending on the type of the XV series acoustic housing, there are 3 options for installing the refrigeration, air conditioning or heat pump device:

1. XV series acoustic housing without bottom is put over the air conditioning or heat pump device as a hood using a crane.
2. The refrigeration, air conditioning or heat pump devices are brought into the acoustic housing from above using a crane.

To do this, the upper lamella package must be removed using quick-release fasteners, and then the flexible air separation part need to be taken out (screw connection). The cooling, air conditioning or heat pumps are lifted in.

Afterwards, the upper lamella package and the flexible air separation part must be reinstalled.

3. The refrigeration, air conditioning or heat pump devices are inserted into the soundproof housing.

Then the refrigeration, air conditioning or heat pump device to be installed is placed on a pedestal that is the same height as the cross member (e.g. made of 2-3 wooden pallets) and pushed horizontally into the soundproof housing:



Align refrigeration, air conditioning or heat pumps in the middle of the air separation part

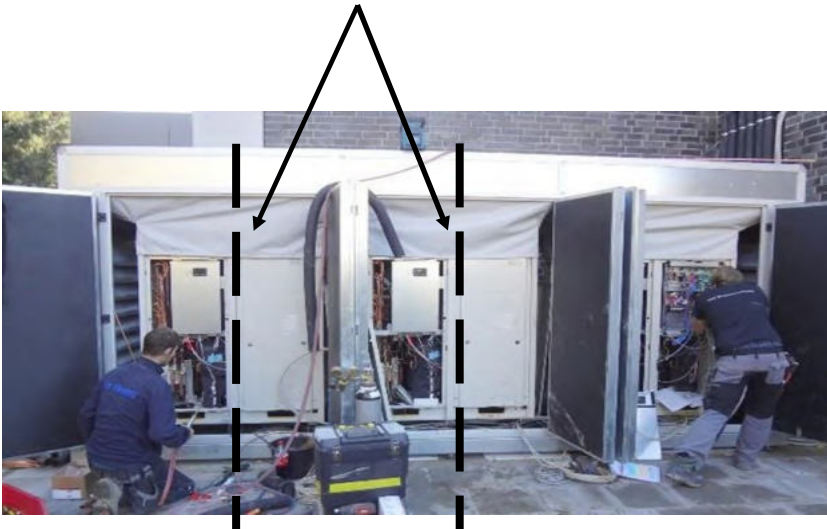

⚠ WARNING

It is important that the alignment of the refrigeration, air conditioning or heat pump device is in the middle of the air separation part.

In order to facilitate the drilling of the housing bushings for pipes and electrical cables as well as the connection work on the refrigeration, air conditioning or heat pump device, we recommend dismantling the necessary lamella packs using the quick-release fasteners with the special key supplied.

Appropriate pipe and cable bushings can then be drilled into the housing.

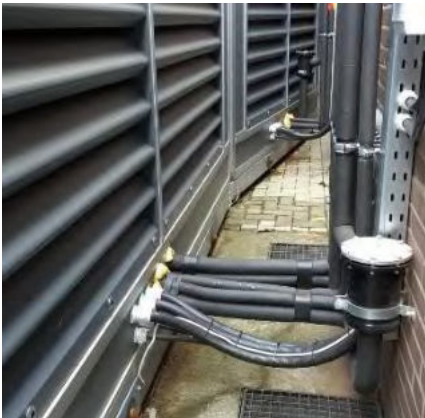

⚠ WARNING

Other openings or large cut-outs in the soundproof housing are not permitted, as this change in the housing entails massive restrictions in terms of the achievable insertion loss and noise reduction, as well as stability and weather resistance.

The further connection and commissioning work on the air conditioning refrigeration device is identical to normal installation without a soundproof housing.

Exact separation of the suction and discharge air flow provided by a flexible, tailor-made, airtight air separator between the upper lamella-pack and the outdoor unit. The flexible air separator is fixed by the installation company on the outer edge of the outdoor unit with foam rubber band and tapping screws, included in the delivery.



Manual XV Acoustic housing

7 Maintenance and Service

7.1 General

For maintenance and service work on the refrigeration, air-conditioning or heat pump unit, the necessary panels can be easily removed from the acoustic housing.

Cleaning and maintenance of the acoustic housing

- Remove other dirt with a dampcloth; if necessary, use grease- or oil-dissolving detergents (concentrated neutral detergent with pH between 8 and 9)
- Treat galvanized parts with preservation spray.
- Regularly lubricate moving parts such as panel locks with a lubrication spray.
- Regularly treat seals
- Repair any damage to the coating, including areas that show signs of corrosion, with repair paint.
- Clean the unit thoroughly to remove all construction dust and other dirt.
- Prior to shipping, each unit is carefully inspected at our factory.

7.2 Silencers

The sound insulation material of the silencers should be checked for dust during major maintenance work and if necessary, cleaned with a vacuum cleaner.

The surface and inside of the backdrop must not be damaged in order to prevent water from being sucked into the foam through damage / openings on the film surface.

If necessary, the silencers must be checked for free passage, as this is necessary for perfect air circulation and the function of the installed refrigeration air conditioning or heat pump unit.

7.3 Air separation

The air separation should be fixed via the refrigeration, air conditioning or heat pump unit and must be checked annually for contamination and damage. Deposited leaves, paper, etc. must be removed.



7.4 Drain Pan

The condensate pan and the drain must be checked for dirt deposits and cleaned if necessary, in any case before the heating season.

NOTICE

A separate heating of the condensate pan is to be decided by the system manufacturer according to the specific requirements of the project and the installed devices.

7.9 Grounding

Depending on the local regulations and position, we recommend to carry out a grounding or lightning protection.

7.10 Test run

After working on the acoustic housing, the person responsible must ensure that no person is in the acoustic housing before it is put into operation again.

7.11 Removal and disposal

Metal parts and plastic parts are to be recycled, per applicable regulations.

7.12 Maintenance table for the soundproof housing

Manu facturer	Component	Activity			Maintenance				
		Controlling	Cleaning	Maintenance	Weekly	Monthly	1/4 annually	1/2 annually	annually
Solflex	Lamellas/Scenes	X	X					X	
	Air seperation	X	X						X
	Drain Pan/ Condensate	X	X					X	
	Housing	X	X						X
	Doors	X		X					

Do you have anymore questions?



Solflex GmbH
Am Feuerstein 282
A-2392 Wienerwald, Austria
+43223820336, office@solflex.eu
XV-IM-10/2021-ENG