



# Installation - Manual

HC(S) - Acoustic Housing

**Solflex GmbH  
Am Feuerstein 282  
2392 Wienerwald  
Austria**

**T: +43223820336  
E: [office@solflex.eu](mailto:office@solflex.eu)  
[www.solflex.eu](http://www.solflex.eu)**

**ATU 65324348  
FN 337206t**

**Always observe all relevant standards and  
statutory regulations**

Subject to change without prior notice.

All business transactions based on our Terms and Conditions, available at  
[www.solflex.eu](http://www.solflex.eu)

## Table of Content

<b>1.</b>	<b>Technical data .....</b>	<b>4</b>
<b>2.</b>	<b>Warranty .....</b>	<b>4</b>
<b>3.</b>	<b>Safety .....</b>	<b>5</b>
3.1	Intended use .....	5
3.2	Safety instructions .....	5
3.2.1.	Risks during unloading and transportation.....	5
3.2.2.	Risk of damage to property and the environment .....	5
3.3.	Emergency procedures .....	5
3.3.1.	Fire fighting.....	5
<b>4.</b>	<b>Product delivery .....</b>	<b>6</b>
<b>5.</b>	<b>Installation of unit .....</b>	<b>7</b>
5.1	HC(S) with rear intake .....	9
5.2	HC(S) with lateral intake .....	10
5.3	Installation with HCFIXBEAM(VI) .....	11
5.4	Installation with HCWMS(VI) .....	12
5.5	HCDRAINPAN(VI).....	13
5.6	Connection for refrigerant pipes and power supply.....	15
5.7	Foundation .....	16
5.8	Installation of Heat Pump, Air Conditioning and Refrigeration outdoor unit .	19
<b>6.</b>	<b>Maintenance and Service .....</b>	<b>19</b>
6.1	General.....	19
6.2	Silencers .....	19
6.3	Grounding .....	20
6.4	Test run .....	20
6.5	Removal and disposal .....	20

## 1. Technical data

<https://solflex.eu/en/hcschalldaemmgehaeuse10db>

<https://solflex.eu/en/hcsschalldaemmgehaeuse14db>



## 2. Warranty

24 months from delivery.

### 3. Safety

In the event of improper operation or operation for a purpose other than the intended, there is however a risk of serious or even fatal injury to persons and a risk of damage to the unit and other property.

#### 3.1 Intended use

The unit must only be used as acoustic housing for compatible Heat Pump, Air Conditioning and Refrigeration systems. Any other use is strictly prohibited.

#### 3.2 Safety instructions

All work about the assembly, installation and commissioning of the unit must be carried out by specially trained technicians.

#### NOTICE

It is possible to get injured during the mounting because of the metal execution and processing. Please wear gloves.

#### 3.2.1. Risks during unloading and transportation

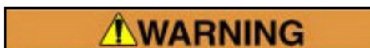

Risk of serious injury from dislodged loads.

Do not stand under suspended loads.

Risks from electric power.

Risk of electric shock from electrostatic charge of housing:  
Earth the device.

#### 3.2.2. Risk of damage to property and the environment

#### NOTICE

Serious damage to property from dropping loads; please observe the instructions in section "Delivery of product". Serious damage to heat exchanger connections, panelling and other mounted components from force impact during moving of unit elements; **always move the unit elements by their base frame.**

Risk of damage to components from heavy impact, e.g. when attempting to dislodge a part with a hammer, etc.: **Components that rest on the foundation must only be moved by shifting.**

#### 3.3. Emergency procedures

##### 3.3.1. Fire fighting

Strictly adhere to all statutory fire safety regulations.

The insulation foam has a fire behaviour according norm.

#### 4. Product delivery

Upon delivery, inspect the product for damage caused during transport and ensure the delivery is complete. Record any damage or missing parts on the transport documents. Complaints regarding obvious transport damage or incomplete deliveries cannot be considered if made too late.

On the construction site, protect the unit against dirt, impact and the elements.

#### 4.1. Unloading / transport to location of installation

This unit is shipped in parts on a pallet. For unloading, lift the unit by the pallet. Too short forks can damage the acoustic housing.



Risk of serious injury or damage to property from dropping loads. Observe the safety instructions of the transport equipment and lifting gear.

Do not climb onto the unit.

#### 4.2 Information on the storage of products made from AluZink

Please note the following: If stored improperly, products made of AluZink can be damaged by corrosion, also known as "white rust". In order to minimize the risk of white rust, suitable precautions must be taken during transport and storage. All products made of AluZink should preferably be stored inside, or with a suitable cover outside, in a clean and dry place away from any chemical contamination. To avoid white rust, AluZink should, as far as possible, be stored at constant temperatures above the dew point. Rapid changes in temperature lead to condensation and subsequently to white rust. In addition, the products made of AluZink must always be stored on pallets made of wood or metal in order to avoid direct contact with the floor.

It is recommended not to store products made of AluZink outdoors. If this is unavoidable, however, it is important to observe the following precautionary measures: Set up a scaffolding around the stored material and cover it with a waterproof film, tarpaulin or similar cover. Leave enough space between the cover and the packages or coils to allow air to circulate. Store the parcels at a slight incline so that rainwater can drain away without touching the ground. Check the storage area at regular intervals to avoid getting wet on the material. Note that all products (stored above, in the middle or below) can also get wet due to nighttime condensation and this water cannot evaporate. Keep the period of storage outdoors as short as possible, especially during the summer months, the rusting process is greatly accelerated by the higher temperatures.

## 5. Installation of unit

### NOTICE

At the place of installation, it must be possible to provide impeccable service and maintenance and the necessary air intake of the built-in air-conditioning, refrigeration and heat pump units.

**When planning the installation site, the guide lines for minimum distances around the air-conditioning, refrigeration and heat pump manufacturer must be respected.**

The **acoustic louvre**, on the suction and exhaust sides has a **depth of 200mm** and the site must enable this to remove to have access to the built-in air conditioning, refrigeration and heat pump equipment.

### **Important NOTE:**



Please always use the required safety work gear during installation. Due to the packaging materials and the production process, personal injury may occur, such as hand injuries.

If the soundproof housing is freely accessible, the necessary measures during assembly should be taken to local conditions to avoid personal injury.

### **Aluzinc**



“The warranty applies to all buildings exposed to normal atmospheric corrosion factors, in other words excluding those subject to permanent spraying with fresh water or salt water; in the case of buildings situated in coastal areas, excluding those exposed to sea spray.”

## Usage limitations of Aluzinc

Like most other metallic-coated steel sheet, Aluzinc® is not recommended:

- When in contact with copper, lead, moist concrete and in alkaline environments.
- In cattle sheds (ammoniac vapours)

For fixings, only use accessories made from:

- Aluzinc®
- Aluminium
- Stainless steels
- Synthetic material (nylon)

### **Important NOTE:**

1. Due to the production process there can appear a minor possibility that oxidation of certain cutting edges become visible. This oxidation is locally and does not affect the rest of the acoustic cabin. This can be prevented by optionally ordering the acoustic cabin powder painted in a specific RAL colour. Alternatively, the oxidation can be post treated with applying manually Alu-Zinc paint (which is common available) from aesthetic point of view.

2. The tightening torque of the screw must be 5 to 15 Nm, so that the screw does not cut into the housing and damages the Aluzinc coating.



## 5.1 HC(S) with rear intake

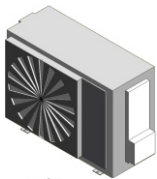

Heat pump

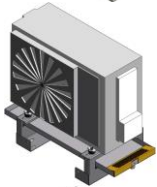

Heat pump supports +  
silentblocks +  
condensate drain pan

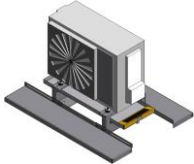

Support brackets

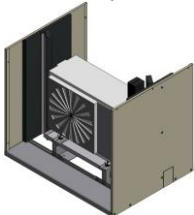

Side panels

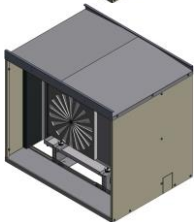

Roof

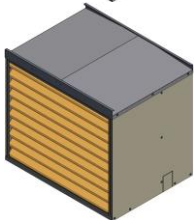

Acoustic grid

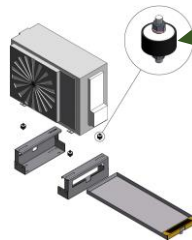

Silentblock M8 Ø40 H20  
Washer Ø8x24  
Nut M8

1) Fix heat pump to support feet  
with silentblocks

2) Insert drain pan (optional)

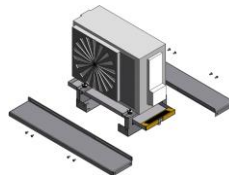

3) Fix support brackets to heat  
pump support feet  
with 8 M8x20 screws

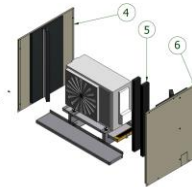

4) Fix side panel to support  
brackets with 4 M8x20 screws

5) Cut to size and apply the  
adhesive polyester provided  
(HCSEP100)

6) Fix side panel to support  
brackets with 4 M8x20 screws

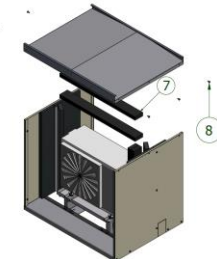

7) Cut to size and apply the  
adhesive polyester provided  
(HCSEP100\*)

(It can be added the HCSEPPLATE: it consists of a  
metal sheet T plus a  
polyester stripe on its side. To be made with a  
customized height and  
to be inserted by interference between the top of the  
heat pump and  
the bottom of the roof)

8) Fix roof to side panels with 6  
M8x20 screws

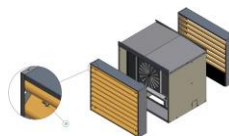

9) Insert acoustic grids in the  
structure

10) Fix acoustic grid to side  
panels with M8x20 screws  
Fix back panel to side panels  
with M8x30 screws

## 5.2 HC(S) with lateral intake

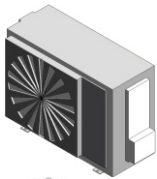

Heat pump

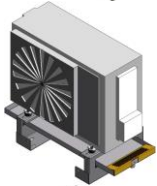

Heat pump supports +  
silentblocks +  
condensate drain pan

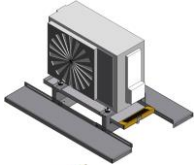

Support brackets

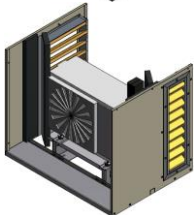

Side panels with big and  
small acoustic grid

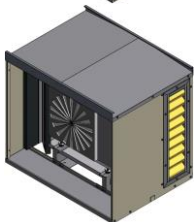

Roof

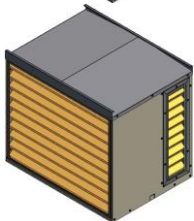

Acoustic grid and rear  
panel

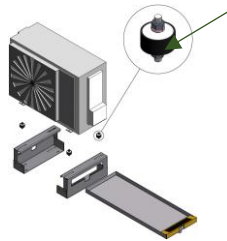

Silent Block M8 Ø40 H20  
Washer Ø8x24  
Nut M8

1) Fix heat pump to support feet  
with silentblocks

2) Insert drain pan (optional)

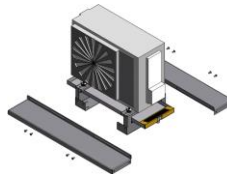

3) Fix support brackets to heat  
pump support feet  
with 8 M8x20 screws

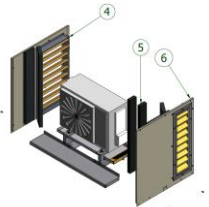

4) Fix side panel to support  
brackets with 4 M8x20 screws

5) Cut to size and apply the  
adhesive polyester provided  
(HCSEP100)

6) Fix side panel to support  
brackets with 4 M8x20 screws

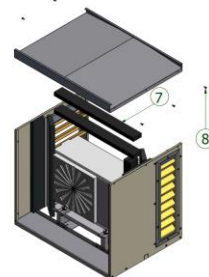

7) Cut to size and apply the  
adhesive polyester provided  
(HCSEP100\*)

(It can be added the HCSEPPLATE: it consists of a  
metal sheet T plus a  
polyester stripe on its side. To be made with a  
customized height and  
to be inserted by interference between the top of  
the heat pump and  
the bottom of the roof)

8) Fix roof to side panels with 6  
M8x20 screws

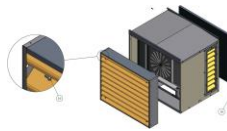

9) Insert acoustic grid and back  
panel in the structure

10) Fix acoustic grid to side  
panels with M8x20 screws  
Fix back panel to side panels  
with M8x30 screws

### 5.3 Installation with HCFIXBEAM(VI)

Installation with HCFIXBEAM(VI) is used for already installed heat pumps.

The steps must be executed in the same order as seen on page 9 and page 10. Just step 1 and step 2 are different:

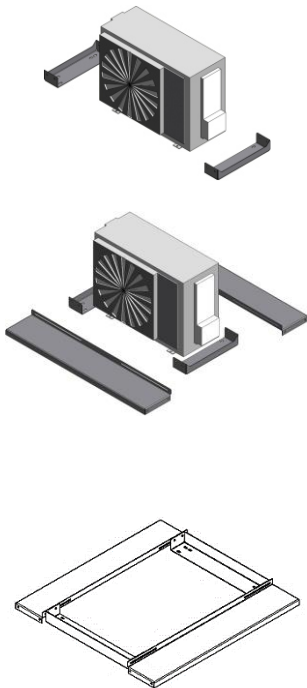

If the heat pump is already in place, it is necessary to use the HCFIXBEAM to fix the cabin to the ground. Place the HCFIXBEAM as shown in the image, taking care to meet the slots of the support brackets of the cabin

Fix support brackets to heat pump support feet with 8 M8x20 screws

## 5.4 Installation with HCWMS(VI)

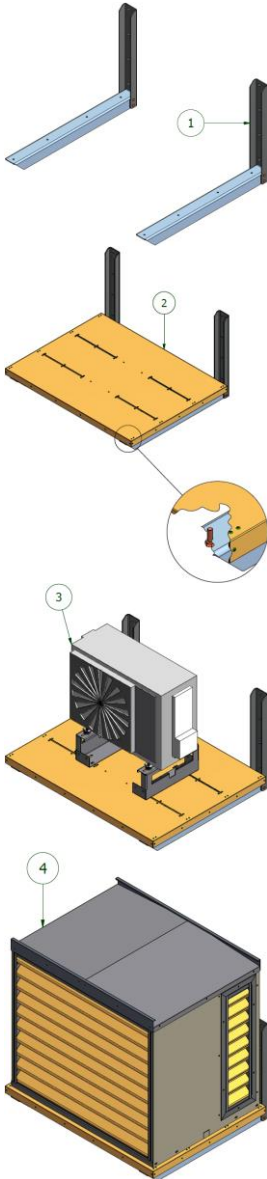

1) Fix the support brackets to the wall via max. Ø14mm screws.

2) Fix the panel to the support brackets through the provided M10 screws, inserting them from the bottom

3) Fix the heat pump supports to the M8 nuts placed inside the panel slots

4) Assemble the cabin as shown into its separate instructions

## 5.5 HCDRAINPAN(VI)

Condensate tray made of aluminum, including temperature-controlled electronic condensate tray heating, leaf retention grid and oil separator.

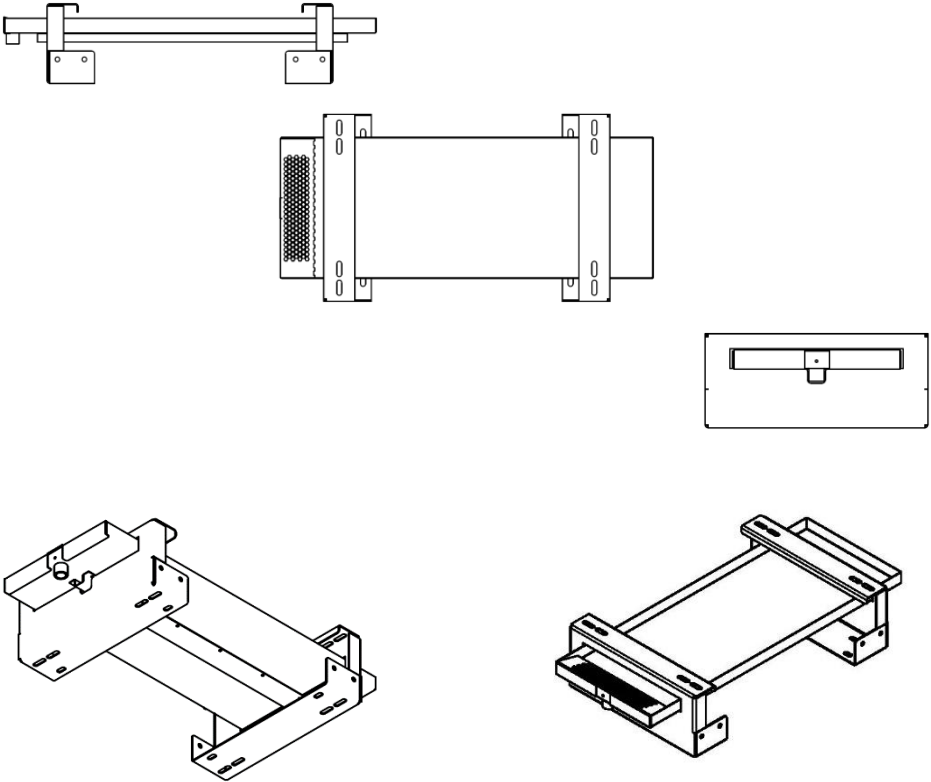

Condensate tray heating 25 FSR2-CT self-regulating 25W at 5° C  
25W / 230VAC / minimum 6A

**Certification**

ATEX - Sira 02ATEX3070

IECEX - SIR 11.0121

VDE - 114665

**Anschluss**

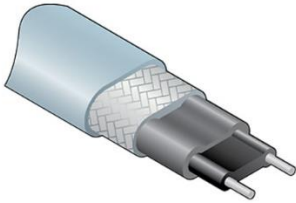

FSR..CT/CF

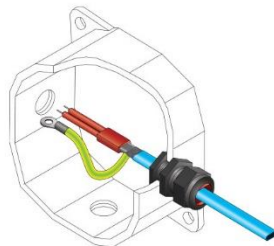
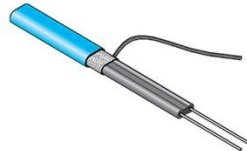
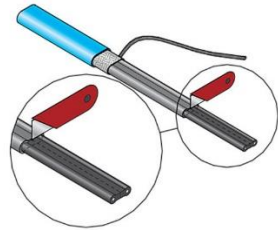
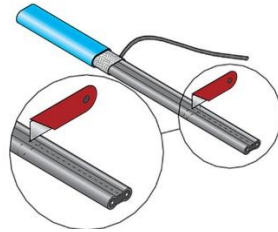
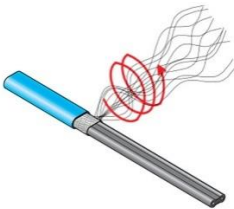
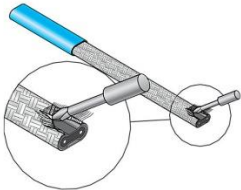

## 5.6 Connection for refrigerant pipes and power supply

There is a possibility to enter with refrigerant pipes and power supply in the sound insulation housing, both on the left and on the right side, in case the entry is not foreseen through the bottom.

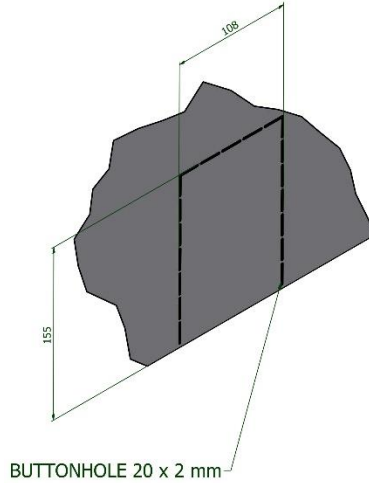

## 5.7 Foundation

The foundation must meet the relevant static and sound propagation requirements and must feature a proper drain for water. It must be level and smooth. The resonance frequency of the support structure must be distinctly different from the excitation frequency of the rotating machine components (Heat Pump, Air Conditioning and Refrigeration system).

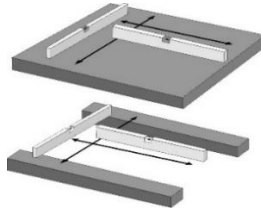

An uneven foundation might cause malfunction or jammed panels. Liability is excluded for damage caused by installation on an uneven surface.

### Foundation example:

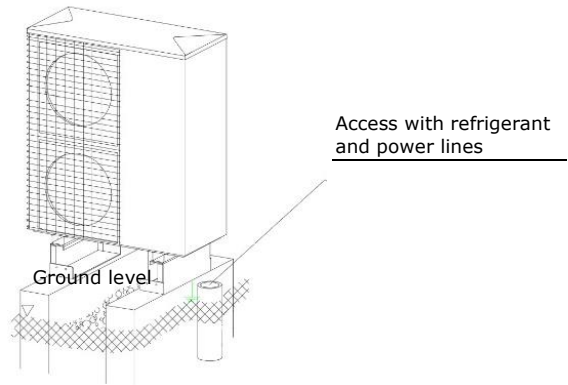
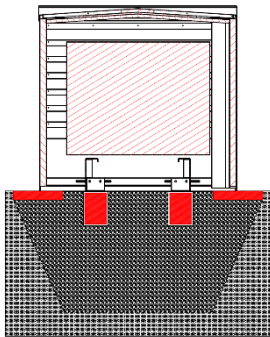



**More examples for a possible foundation**



**Dimensions of foundations:**

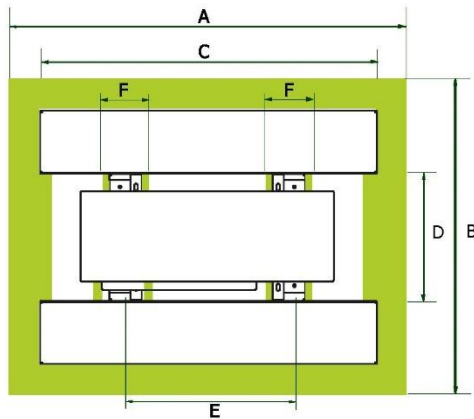

Type	Dimensions Foundation [mm]					
	A	B	C	D	E	F
HC(S)100NP(INOX)	1300	1000	1050	450	Distance between the support feet of the HVACR unit	160
HC(S)Y100NP						
HC(S)200NP(INOX)						
HC(S)Y200NP						
HC(S)100NPSA(INOX)						
HC(S)Y100NPSA						
HC(S)200NPSA(INOX)						
HC(S)Y200NPSA						
HC(S)100NPVI	1500	1250	1250	700	Distance between the support feet of the HVACR unit	160
HC(S)Y100NPVI						
HC(S)200NPVI						
HC(S)Y200NPVI						
HC(S)100NPSAVI						
HC(S)Y100NPSAVI						
HC(S)200NPSAVI						
HC(S)Y200NPSAVI						

**Note 1:**

In case of a complete foundation (=AxB), a frost-proof drain of the condensate must be provided locally.

**Note 2:**

Just as with an installation without a soundproof enclosure and if there are no other local regulations that a drain collection should be used as environmental protection, it is possible to drain the condensation water from the heat pump, for example, into a gravel bed, which was carried out professionally for an appropriate water drainage. In addition, a protection against plant growth from below is to ensure.

**5.8 Installation of Heat Pump, Air Conditioning and Refrigeration outdoor unit**



The correct installation position of the air conditioning, refrigeration or heat pump unit is decisive for the fit and function of the acoustic housing.

**6. Maintenance and Service**

**6.1 General**

For maintenance and service work on the refrigeration, air-conditioning or heat pump unit, the necessary panels can be easily removed from the acoustic housing.

**Cleaning and maintenance of the acoustic housing**

- Remove other dirt with a dampcloth; if necessary, use grease- or oil-dissolving detergents (concentrated neutral detergent with pH between 8 and 9).

- Treat galvanized parts with preservation spray.
- Regularly lubricate moving parts such as panel locks with alubrication spray.
- Regularly treat seals.
- Repair any damage to the coating, including areas that show signs of corrosion, with repair paint.
- Clean the unit thoroughly to remove all construction dust and other dirt.
- Prior to shipping, each unit is carefully inspected at our factory.

## **6.2 Silencers**

The sound insulation material of the silencers should be checked for dust during major maintenance work and if necessary, cleaned with a vacuum cleaner.

If necessary, the silencers must be checked for free passage, as this is necessary for perfect air circulation and the function of the installed refrigeration air conditioning or heat pump unit.

## **6.3 Grounding**

Depending on the local regulations and position, we recommend to carry out a grounding or lightning protection.

## **6.4 Test run**

After working on the acoustic housing, the person responsible must ensure that no person is in the acoustic housing before it is put into operation again.

## **6.5 Removal and disposal**

Metal parts and plastic parts are to be recycled, per applicable regulations.

## Notes

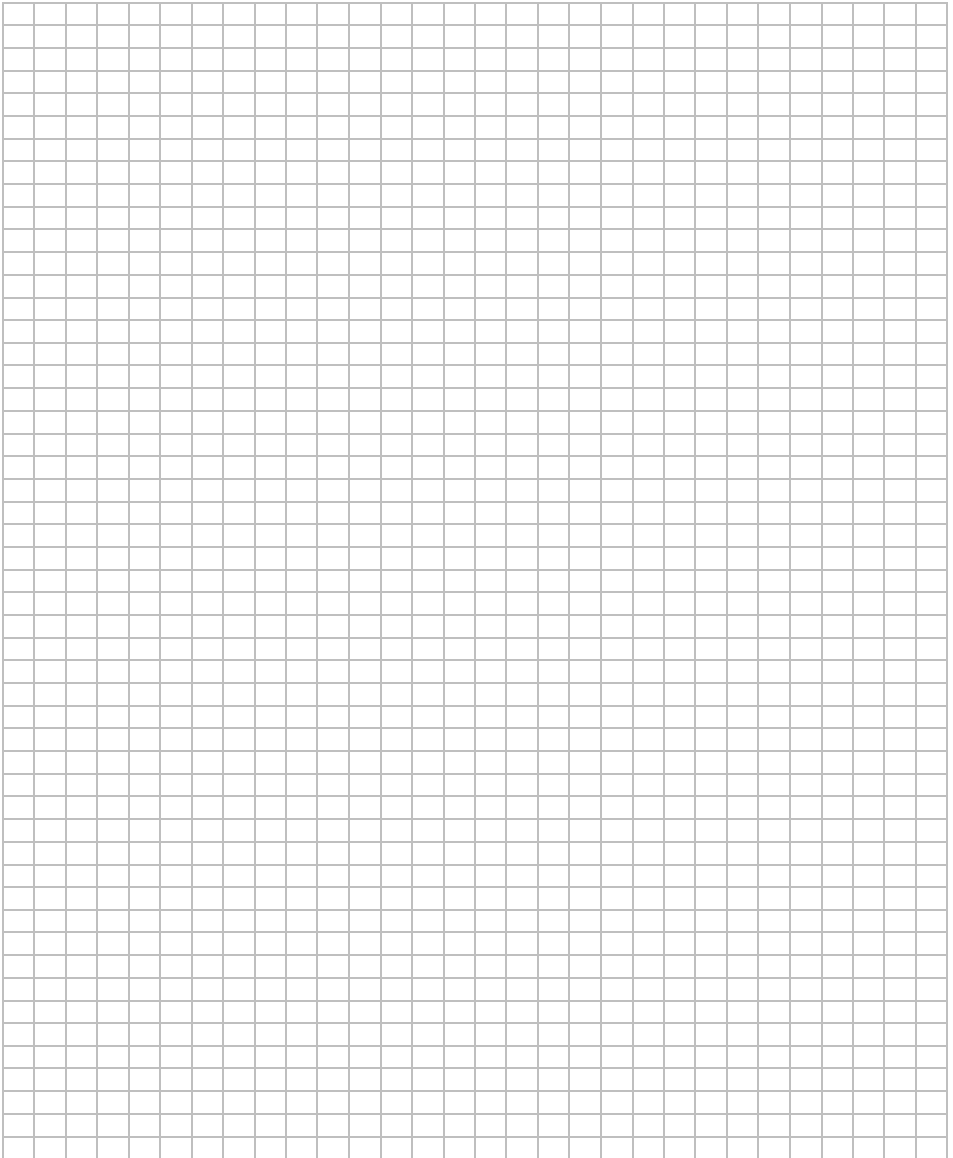
A large grid of graph paper, consisting of 20 columns and 30 rows of small squares, intended for taking notes.

**Do you have anymore questions?**



Solflex GmbH  
Am Feuerstein 282  
A-2392 Wienerwald, Austria  
+43 2238 203 36, [office@solflex.eu](mailto:office@solflex.eu)  
IM-01/2021-ENG